

Dual Differential Magneto-resistive Sensor CY-SMR-04

Features

- The gear rotation direction can be detected by monitoring the phase shift direction of the two output signals A and B
- Wide sensing range, detecting frequency range 0 ~ 100kHz
- Good Signal-to-Noise ratio, high resolution, high sensitivity
- Contactless measurement, easy to use

Typical applications

- Detection of gear rotation speed and direction in factory automation equipments
- Detection of the direction of linear motion servo
- Motor controller for vehicles
- Measurement of needle position in industrial knitting machines

The differential magneto-resistive sensor CY-SMR-04 consists of two groups of two series coupled magneto resistors (D-type InSb/NiSb semiconductor resistors whose value can be magnetically controlled). The magneto resistors are mounted onto an insulated ferrite substrate. The sensor is encapsulated in a metallic and plastic package and has 2 output signals. The phase shift between the two output signals is 90°. A permanent magnet, which supplies a biasing magnetic field, is fixed on the base of the sensor.

Outlines

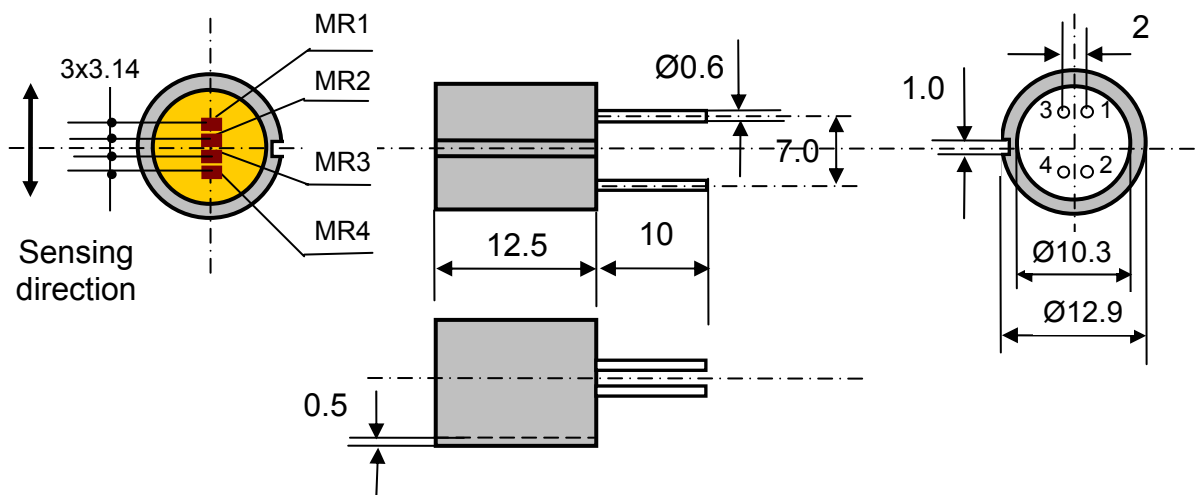

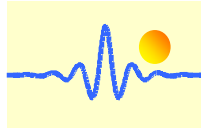

Inner Circuit

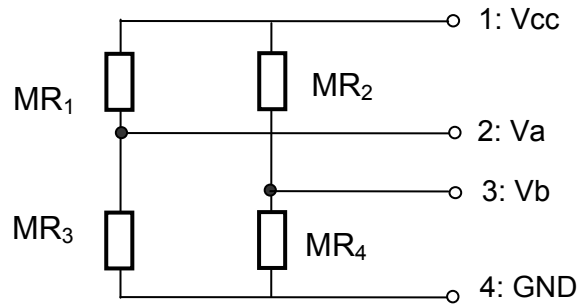

Output Signal Wave

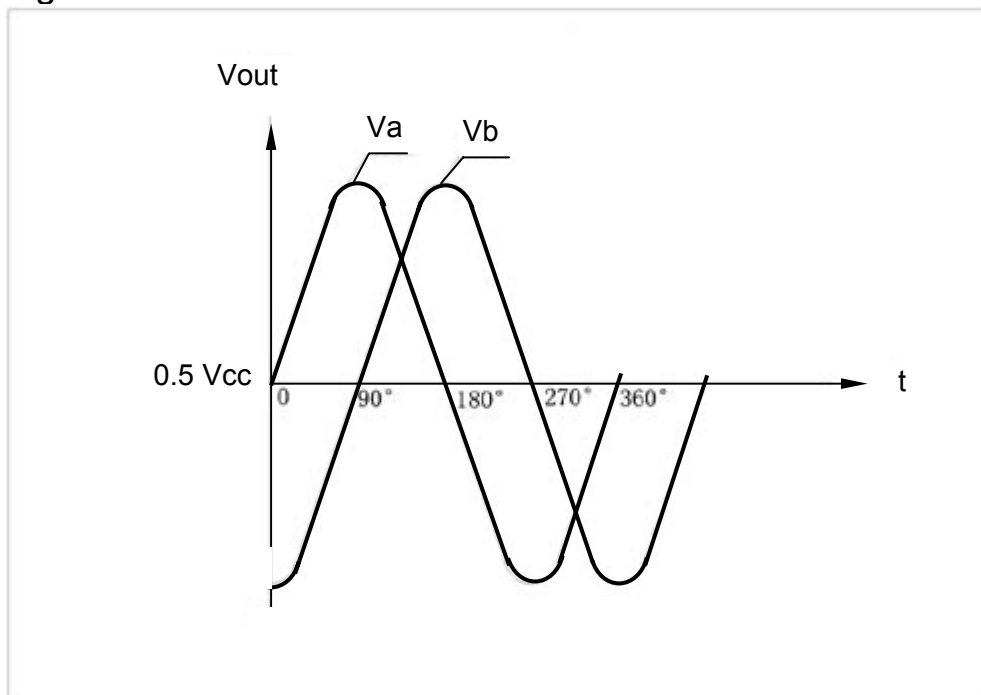

Specifications

Maximum power supply V_{max}	10V DC
Nominal power supply	5V DC
Total resistance R_{14} ($\delta=\infty$, $I \leq mA$, $t=25^\circ C$) $R_{14} = (MR_1+MR_3) \times (MR_2+MR_4) / (MR_1+MR_2+MR_3+MR_4)$	0.5k Ω –3k Ω
Center symmetry $M=100\%$ ($R_{1-2}-R_{2-3}$)/ R_{1-2} ($\delta=\infty$)	$\leq 10\%$
Open circuit output voltage $V_{out\ pp}$ (at V_{in} and gap $\delta=0.15mm$)	$\geq 450mV$
Frequency range	0-100kHz
Target Gear Module	0.4mm
Phase difference between two output signals Va and Vb	$90^\circ \pm 10^\circ$
Operating temperature	$-20^\circ C \sim +80^\circ C$
Storage temperature	$-40^\circ C \sim +85^\circ C$

Part number

Part number	Case style	Outline	Cross reference
CY-SMR-04	Cylinder	$\varnothing 12.9 \times 12.5mm$	MuRata FR05CM12AL